



## Dehumidifier Range

Consorb (CS/DC) Consorb (CZ) Recusorb (DR)  
Recusorb (R/RL) Recusorb (RLZ)



Covering a variety of market sectors

Drinks & Beverage | Chemical & Pharmaceutical | Food Production | Medical & Scientific | Metal Works | Plastics & Rubber

# Consorb (CS/DC)

The CS/DC ranges provide dehumidification according to the 'Consort' principle. As well as the washable D-Max silica gel rotor at the heart of the dehumidifier, each unit includes an electric heater in the regeneration air stream, plus separate supply air / regeneration air fans. We also offer multiple solutions for the control of these units.

Consort (CS/DC)

## Dehumidifying Capacity



0.35 - 3.0 kg/hr

## Dry Air Flow



65 - 550 m<sup>3</sup>/hr

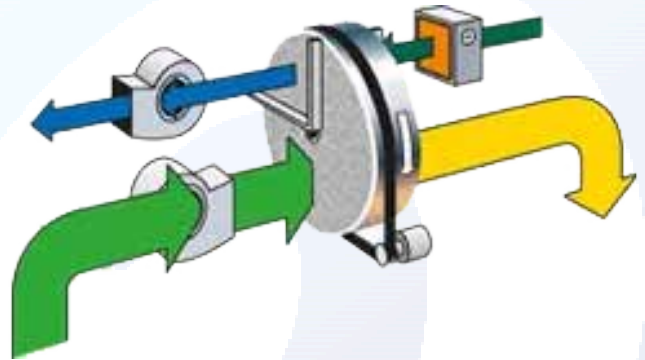

## Typical Applications



Flood & water damage, temporary humidity control, museums, research laboratories, silo headspace conditioning, dry air stores, small production processes.

## Operating Principle



The Consorb principle is normally used at low regeneration temperatures, e.g. when surplus heat is available or when dehumidifying very damp air. The Consorb principle is also good when there is a large difference in moisture content between process and regeneration air inlets.



Get in touch with one of our expert team today.

☎ 01422 371711 ✉ [sales@newsome.ltd.uk](mailto:sales@newsome.ltd.uk) 🌐 [www.newsome.ltd.uk](http://www.newsome.ltd.uk)

**Your trusted temperature & humidity control partner**

# Consorb (CZ)

The CZ industrial range provides dehumidification for larger applications according to the 'Consorb' principle. As well as the washable D-Max silica gel rotor at the heart of the dehumidifier, each unit includes heating in the regeneration air stream (either electric, hot water, steam or gas heating is available), plus separate supply air / regeneration air fans. We also offer multiple solutions for the control of these units.

'When necessary - additional modules can be provided. Pre-cooling modules can be provided to increase system efficiency - while post-cooling modules can be provided to ensure supply air is delivered at the correct condition for the process/application.'

Consorb (CZ)

## Dehumidifying Capacity



19 - 65 kg/hr

## Dry Air Flow



3,200 - 12,000 m<sup>3</sup>/hr

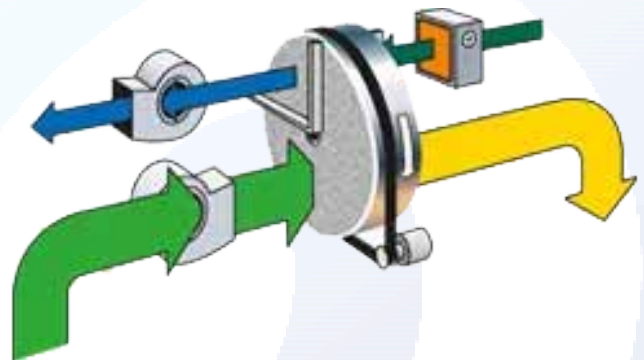

## Typical Applications



Chemical, pharmaceutical & food manufacturing processes, large warehouses, cold stores, ice rinks & sports halls.

## Operating Principle



The Consorb principle is normally used at low regeneration temperatures, e.g. when surplus heat is available or when dehumidifying very damp air. The Consorb principle is also good when there is a large difference in moisture content between process and regeneration air inlets.



Get in touch with one of our expert team today.

☎ 01422 371711 ✉ [sales@newsome.ltd.uk](mailto:sales@newsome.ltd.uk) 🌐 [www.newsome.ltd.uk](http://www.newsome.ltd.uk)

**Your trusted temperature & humidity control partner**

# Recusorb (DR)

The DR range provides dehumidification according to the 'Recusorb' principle which utilises integrated heat recovery. As well as the washable D-Max silica gel rotor at the heart of the dehumidifier, each unit includes an electric heater in the regeneration air stream, plus a single fan providing both supply / regeneration air flows. We also offer multiple solutions for the control of these units.

Recusorb (DR)

## Dehumidifying Capacity



0.5 - 2.8 kg/hr

## Dry Air Flow



190 - 600 m<sup>3</sup>/hr

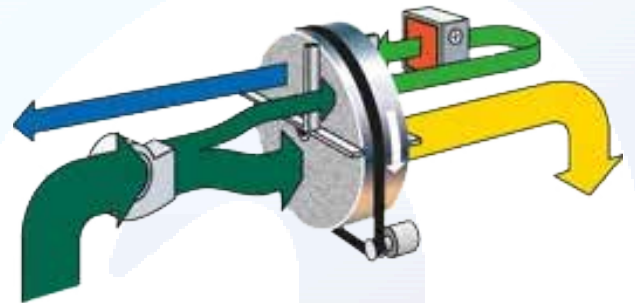

## Typical Applications



Flood & water damage, temporary humidity control, museums, research laboratories, silo headspace conditioning, dry air stores, small production processes.

## Operating Principle



The Recusorb 'R' principle utilises heat recovery. During the rotor's regeneration - heat is absorbed then recycled in the 'purge zone' - where incoming air is preheated & partially dehumidified. Energy consumption is reduced as the dry air becomes both drier & cooler compared to traditional sorption dehumidifiers.



Get in touch with one of our expert team today.

☎ 01422 371711 ✉ sales@newsome.ltd.uk 🌐 www.newsome.ltd.uk

**Your trusted temperature & humidity control partner**

# Recusorb (R/RL)

Recusorb (R/RL)

The R/RL industrial ranges provides dehumidification for mid-size applications according to the 'Recusorb' principle which utilises integrated heat recovery. As well as the washable D-Max silica gel rotor at the heart of the dehumidifier, each unit includes heating in the regeneration air stream (either electric or steam heating is available), plus separate supply air / regeneration air fans. We also offer multiple solutions for the control of these units.

'When necessary - additional modules can be provided. Pre-cooling modules can be provided to increase system efficiency - while post-cooling modules can be provided to ensure supply air is delivered at the correct condition for the process/application.'

## Dehumidifying Capacity



4 - 17 kg/hr

## Dry Air Flow



850 - 3,200 m<sup>3</sup>/hr

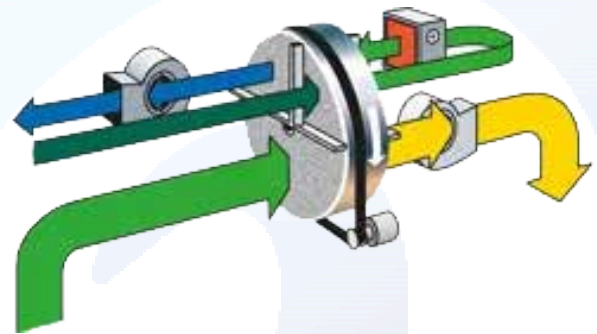

## Typical Applications



Dry air storage, cold stores, sports halls, museums, clean rooms, pneumatic conveying, process air conditioning systems.

## Operating Principle



The Recusorb 'R' principle utilises heat recovery. During the rotor's regeneration - heat is absorbed then recycled in the 'purge zone' - where incoming air is preheated & partially dehumidified. Energy consumption is reduced as the dry air becomes both drier & cooler compared to traditional sorption dehumidifiers.



Get in touch with one of our expert team today.

☎ 01422 371711 ✉ sales@newsome.ltd.uk 🌐 www.newsome.ltd.uk

**Your trusted temperature & humidity control partner**

# Recusorb (RLZ)

The RLZ industrial range provides dehumidification for larger applications according to the 'Recusorb' principle which utilises integrated heat recovery. As well as the washable D-Max silica gel rotor at the heart of the dehumidifier, each unit includes heating in the regeneration air stream (either electric, hot water, steam or gas heating is available), plus separate supply air / regeneration air fans. We also offer multiple solutions for the control of these units.

'When necessary - additional modules can be provided. Pre-cooling modules can be provided to increase system efficiency - while post-cooling modules can be provided to ensure supply air is delivered at the correct condition for the process/application.'

Recusorb (RLZ)

## Dehumidifying Capacity



19 - 70 kg/hr

## Dry Air Flow



2,900 - 12,000 m<sup>3</sup>/hr

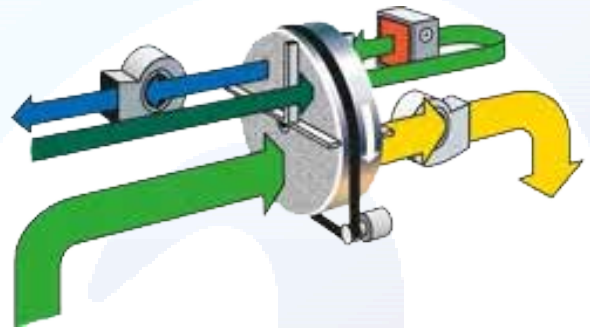

## Typical Applications



Chemical, pharmaceutical & food manufacturing processes, large warehouses, cold stores, ice rinks & sports halls.

## Operating Principle



The Recusorb 'R' principle utilises heat recovery. During the rotor's regeneration - heat is absorbed then recycled in the 'purge zone' - where incoming air is preheated & partially dehumidified. Energy consumption is reduced as the dry air becomes both drier & cooler compared to traditional sorption dehumidifiers.



Get in touch with one of our expert team today.

☎ 01422 371711 ✉ sales@newsome.ltd.uk 🌐 www.newsome.ltd.uk

**Your trusted temperature & humidity control partner**

**Newsome Ltd  
Head Office**

Woodlands Road  
Off Park Road  
Elland  
West Yorkshire  
HX5 9HN

**Newsome Ltd  
South**

Quattro House  
Frimley Road  
Camberley  
Surrey  
GU16 7ER

[www.newsome.ltd.uk](http://www.newsome.ltd.uk)

---

**UK Sales & Hire Team**

T - 01422 371711  
E - [enquiries@newsome.ltd.uk](mailto:enquiries@newsome.ltd.uk)

---

**UK Service & Support Team**

T - 01422 371711  
E - [enquiries@newsome.ltd.uk](mailto:enquiries@newsome.ltd.uk)

---

**Regional Contacts**

**Scotland**

Edinburgh 0131 5263093  
Glasgow 0141 4284352

**Midlands**

Leicester 0116 3032303

**South**

Bristol 0117 2034173  
Watford 01923 901558

---

Your **trusted** temperature and humidity control **partner**